

Thermostat - Moore machine

Design a thermostat that stabilizes the temperature at 22°C with a hysteresis of $\pm 2^\circ\text{C}$. The circuit should work as follows: when the temperature drops below 20°C, the state machine turns on heating, when the temperature rises above 22 °C, it turns off heating. Fluctuation of temperature between 20-24°C should not trigger heating or cooling. When the temperature rises above 24°C, the state machine turns on cooling, when the temperature drops below 22 °C, it turns off cooling. Fluctuation of temperature between 20-24°C should not trigger heating or cooling. The state machine uses three 1-bit digital sensors to measure temperature. Each sensor outputs logic 1 when the temperature is higher than its set threshold, and logic 0 when it is lower. The individual temperature thresholds for each sensor are:

- 24°C (sensor a),
- 22°C (sensor b),
- 20°C (sensor c).

System design as a Moore machine.

Temperature	Sensors indications		
	a	b	c
24°C	1	1	1
22°C	0	1	1
20°C	0	0	1
	0	0	0

Sensor indications (a b c):

> 24°C – 111;

22°C ÷ 24°C – 011;

20°C ÷ 22°C – 001;

< 20°C – 000;

In order to test the system, use the **ThermoObject** module. **ThermoObject** is a control object simulator. The outputs of this object show the states of sensors a, b and c (HEX5 display diodes). Additionally, the **ThermoObject** displays the current temperature on 7-segment displays (HEX2..HEX0). Connect the module as shown in Fig. 2.

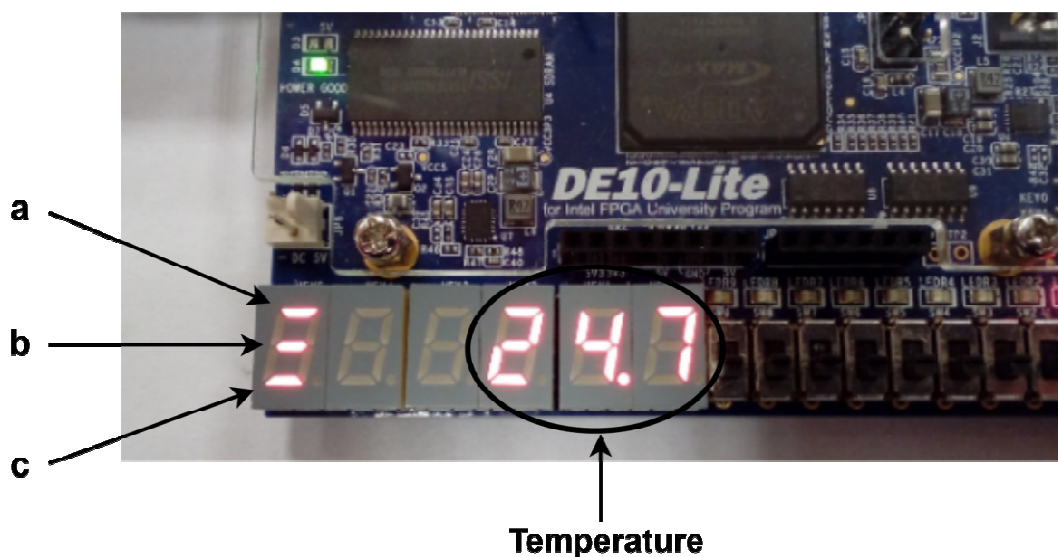

Fig. 1: LED indications corresponding to sensors a, b and c and current temperature in °C

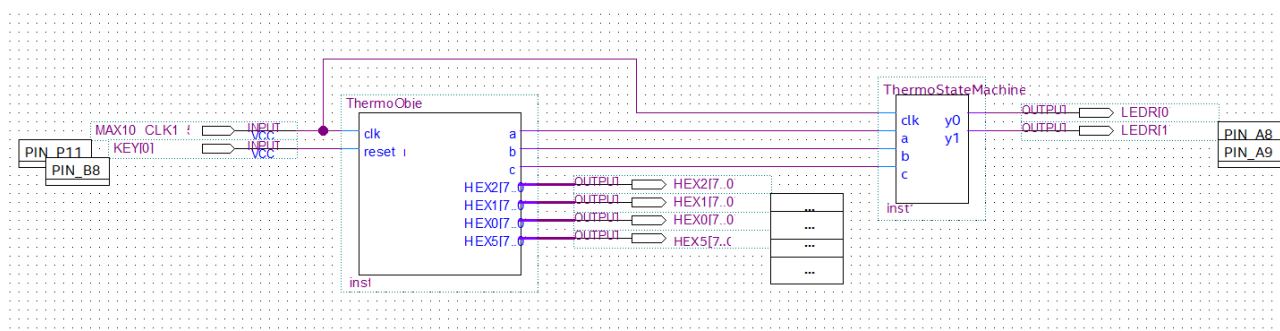

Fig. 2: Connection of the ThermoObject and Moore machine

Synthesis of the Moore machine

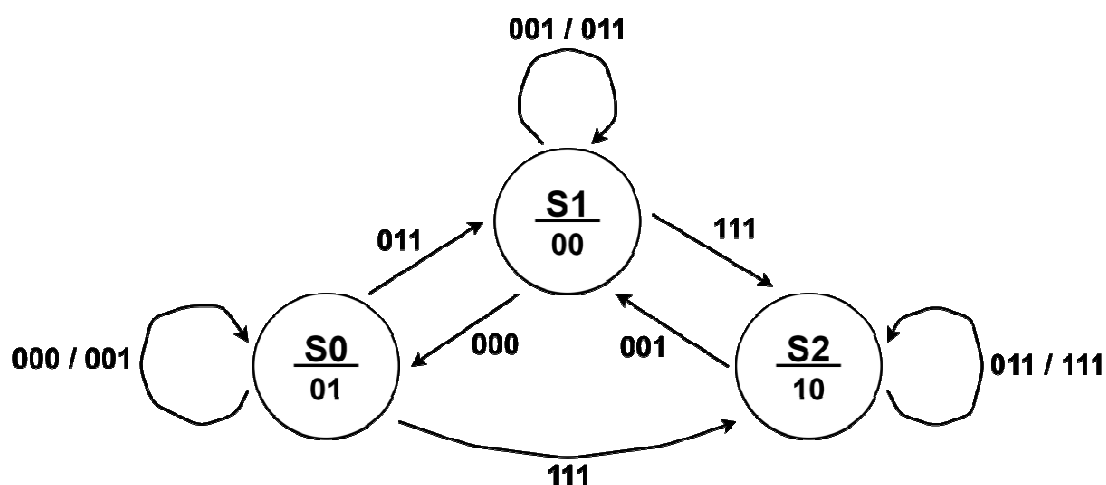

Fig. 3: The state machine graph

(S0 – cooling off / heating on, S1 – cooling off / heating off, S2 – cooling on / heating off)
 000: temp < 20°C; 001: temp 20°C ÷ 22°C; 011: temp 22°C ÷ 24°C; 111: temp > 24°C;

State coding (assignment of binary values):

S0 -> 00

S1 -> 01

S2 -> 10

S _n			X			S _{n+1}		
S _n	q ₁	q ₀	a	b	c	q ₁ '	q ₀ '	S _{n+1}
S0	0	0	0	0	0	0	0	S0
S0	0	0	0	0	1	0	0	S0
S0	0	0	0	1	1	0	1	S1
S0	0	0	1	1	1	1	0	S2
S1	0	1	0	0	0	0	0	S0
S1	0	1	0	0	1	0	1	S1
S1	0	1	0	1	1	0	1	S1
S1	0	1	1	1	1	1	0	S2
S2	1	0	0	0	1	0	1	S1
S2	1	0	0	1	1	1	0	S2
S2	1	0	1	1	1	1	0	S2

Tab. 1: The state transition table of Moore machine

D flip-flops were selected for the synthesis of the Moore machine.

TRANSITION LOGIC:

a b c q ₁ q ₀	000	001	011	010	110	111	101	100
	00	0	0	1	-	-	0	-
01	0	1	1	-	-	0	-	-
11	-	-	-	-	-	-	-	-
10	-	1	0	-	-	0	-	-

$$D_0 = q_1 \bar{b} + q_0 \bar{a}c + \bar{q}_1 \bar{a}b$$

a b c q ₁ q ₀	000	001	011	010	110	111	101	100
	00	0	0	0	-	1	-	-
01	0	0	0	-	-	1	-	-
11	-	-	-	-	-	-	-	-
10	-	0	1	-	-	1	-	-

$$D_1 = a + q_1 b$$

OUTPUT LOGIC:

S _n	S _n		Y	
	q ₁	q ₀	y ₁	y ₀
S0	0	0	0	1
S1	0	1	0	0
S2	1	0	1	0

Tab. 2: The output table of Moore machine

$$y_0 = \bar{q}_1 \bar{q}_0$$

$$y_1 = q_1 \bar{q}_0$$

APPENDIX A – 3x1-bit Sensor System

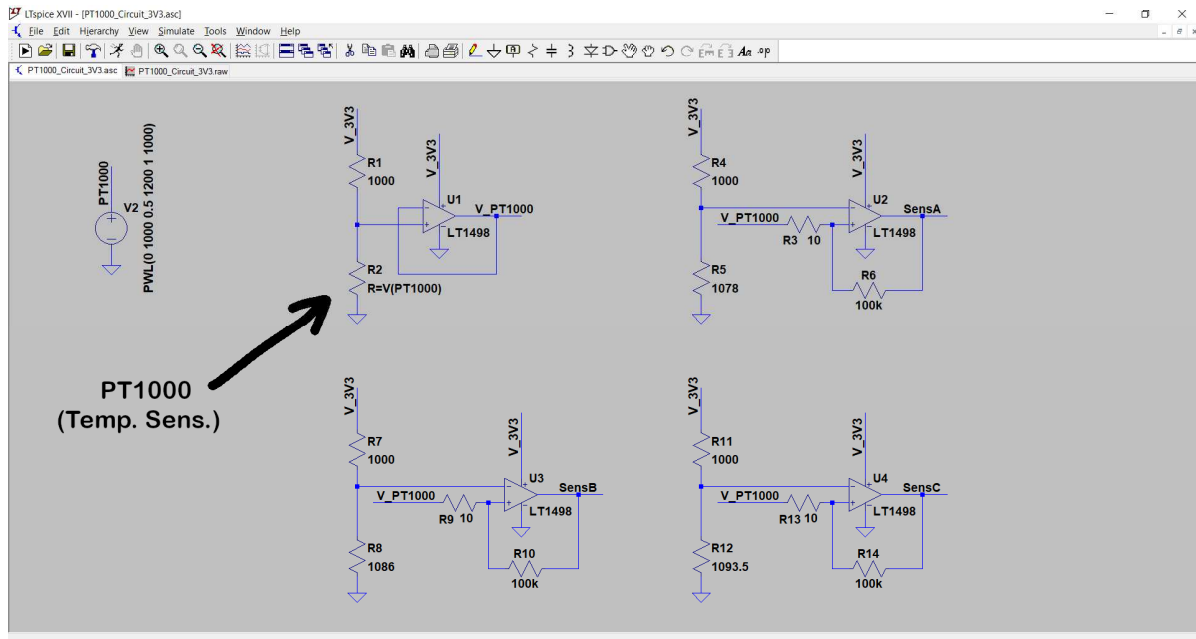

Fig. 4: 3 x 1-bit sensor circuit - LTSpice simulation

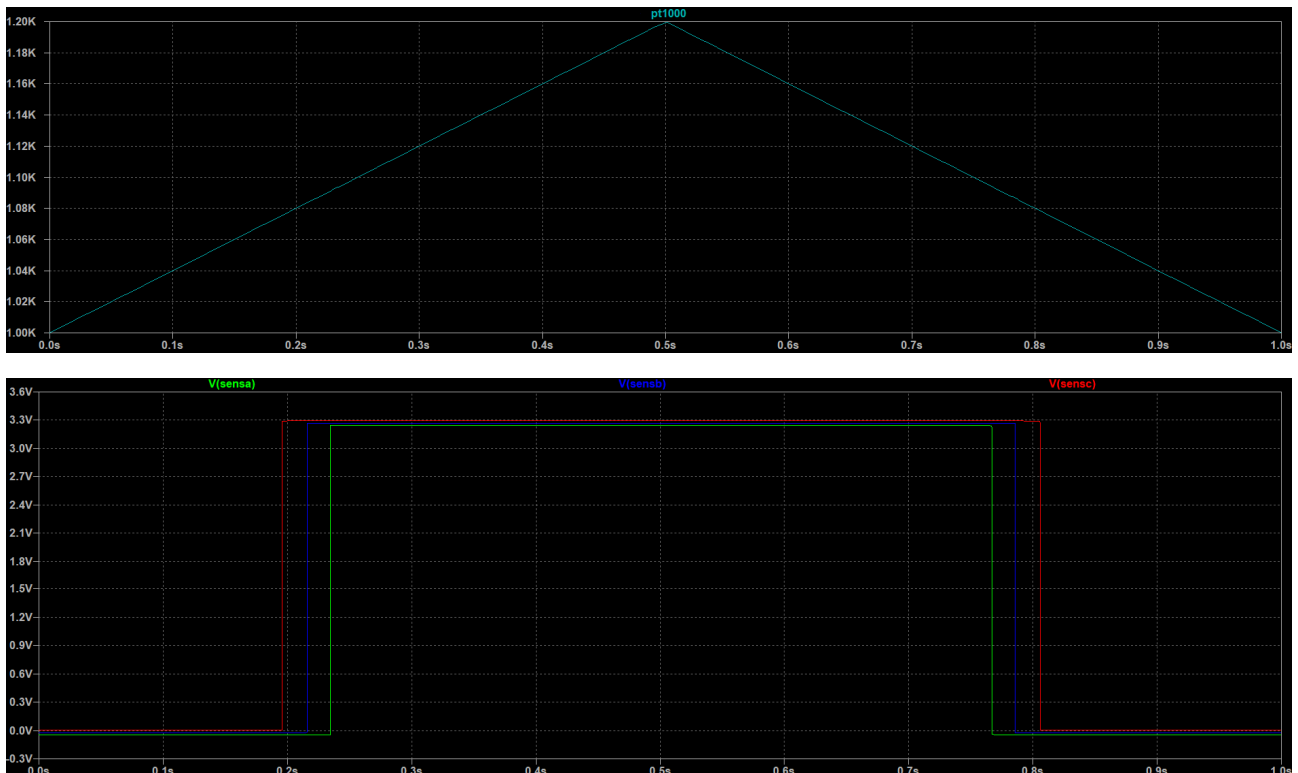

Fig. 5: Results of the simulation of the circuit of 3 1-bit sensors:
 a) change of the PT1000 sensor resistance in the range of 1000 Ω - 1200 Ω (corresponding to the temperature change of 0°C - 52°C); b) state of the digital outputs SensA, SensB and SensC.

NOMINAL RESISTANCE VALUE						
TEMPERATURE (°C)	R/R ₀ RATIO	NOMINAL RESISTANCE VALUES			CLASS F0.3	CLASS F0.6
		R ₀ 100 Ω (Ω)	R ₀ 500 Ω (Ω)	R ₀ 1000 Ω (Ω)	T _{Tol.} (°C)	T _{Tol.} (°C)
-55	0.78319	78.32	391.59	783.19	± 0.58	± 1.15
-50	0.80306	80.31	401.53	803.06	± 0.55	± 1.10
-45	0.82290	82.29	411.45	822.90	± 0.53	± 1.05
-40	0.84271	84.27	421.35	842.71	± 0.50	± 1.00
-35	0.86248	86.25	431.24	862.48	± 0.48	± 0.95
-30	0.88222	88.22	441.11	882.22	± 0.45	± 0.90
-25	0.90192	90.19	450.96	901.92	± 0.43	± 0.85
-20	0.92160	92.16	460.80	921.60	± 0.40	± 0.80
-15	0.94124	94.12	470.62	941.24	± 0.38	± 0.75
-10	0.96086	96.09	480.43	960.86	± 0.35	± 0.70
-5	0.98044	98.04	490.22	980.44	± 0.33	± 0.65
0	1.00000	100.00	500.00	1000.00	± 0.30	± 0.60
5	1.01953	101.95	509.76	1019.53	± 0.33	± 0.65
10	1.03903	103.90	519.51	1039.03	± 0.35	± 0.70
15	1.05849	105.85	529.25	1058.49	± 0.38	± 0.75
20	1.07794	107.79	538.97	1077.94	± 0.40	± 0.80
25	1.09735	109.73	548.67	1097.35	± 0.43	± 0.85
30	1.11673	111.67	558.36	1116.73	± 0.45	± 0.90
35	1.13608	113.61	568.04	1136.08	± 0.48	± 0.95
40	1.15541	115.54	577.70	1155.41	± 0.50	± 1.00
45	1.17470	117.47	587.35	1174.70	± 0.53	± 1.05
50	1.19397	119.40	596.99	1193.97	± 0.55	± 1.10
55	1.21321	121.32	606.60	1213.21	± 0.58	± 1.15
60	1.23242	123.24	616.21	1232.42	± 0.60	± 1.20
65	1.25160	125.16	625.80	1251.60	± 0.63	± 1.25
70	1.27075	127.08	635.38	1270.75	± 0.65	± 1.30
75	1.28987	128.99	644.94	1289.87	± 0.68	± 1.35
80	1.30897	130.90	654.48	1308.97	± 0.70	± 1.40
85	1.32803	132.80	664.02	1328.03	± 0.73	± 1.45
90	1.34707	134.71	673.53	1347.07	± 0.75	± 1.50
95	1.36608	136.61	683.04	1366.08	± 0.78	± 1.55
100	1.38506	138.51	692.53	1385.06	± 0.80	± 1.60

Fig. 6: Table of discrete values of the PT1000, based on the sensor characteristics