

## Combinational circuit for controlling a 7-segment display

### Requirements for the exercise (issues and skills necessary to complete the task):

- representation of numbers in decimal, binary and hexadecimal systems;
- setting up a new project in Quartus Prime;
- creating a hardware module (symbol) in Quartus Prime based on a schematic file (\*.bdf);
- creating a hardware module (symbol) in Quartus Prime based on a source code file (eg. \*.vhd);
- ability to simplify a logical expressions using the Karnaugh Map method;
- ability to implement a scheme with logic gates based on an algebraic equation.

The 7-segment display is commonly used to represent digits in electronic devices such as clocks, calculators, and counters. It is also used in electronic scales, control panels of household appliances, digital thermometers, as well as simple measurement displays in laboratory and industrial equipment. It can also display simple commands such as: OPEN / CLOSE / ON / OFF / HALLO / FULL itd.



Decimal Digits 0-9

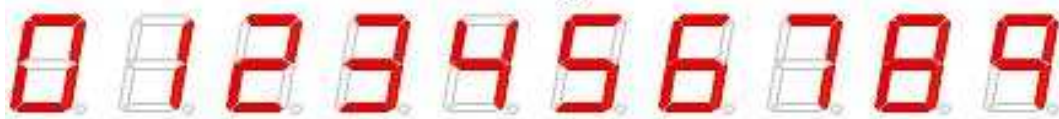

Select Alpha Characters



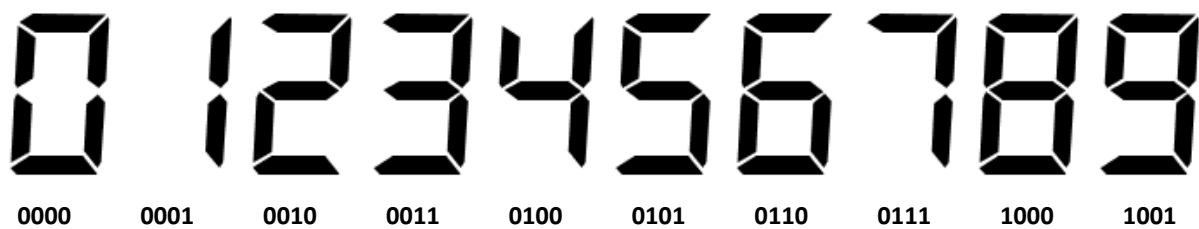

**Example:**

Design combinational logic circuit to control a 7-segment display. The input is a 4-bit number in BCD format. On the outputs have to appear seven signals to control each display's diodes. Furthermore, for the bit combination 1010 and 1011 on display have to appear special character. The other combinations of bits (1100, 1101, 1110, 1111) don't belong to the domain of the function. **Design the system in the form of a schematic with logic gates.**

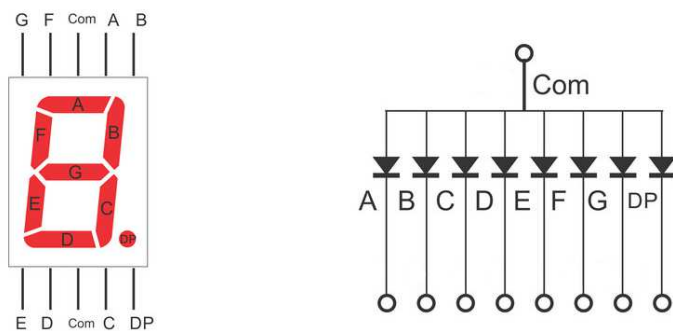
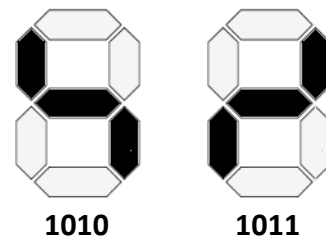

Fig. 1: 7-segment display with a common anode

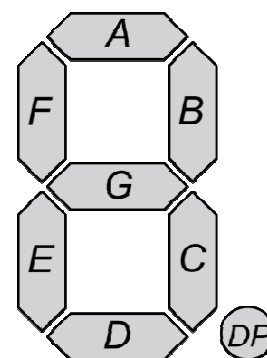

Fig. 2: Arrangement of the segments

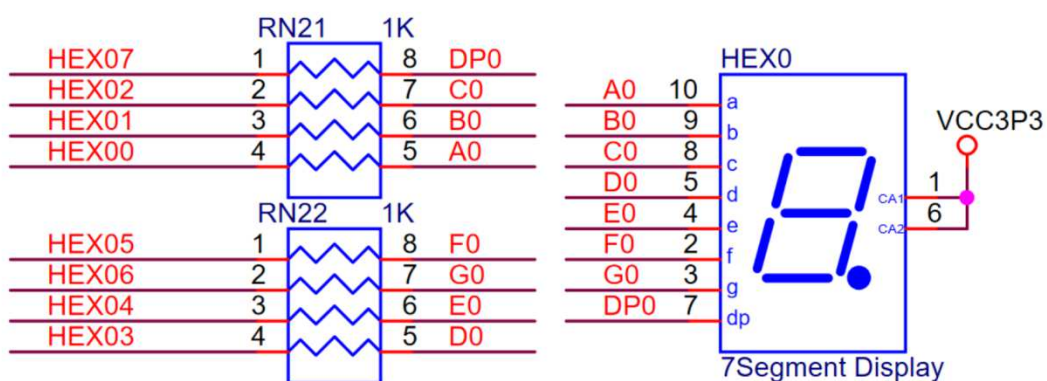
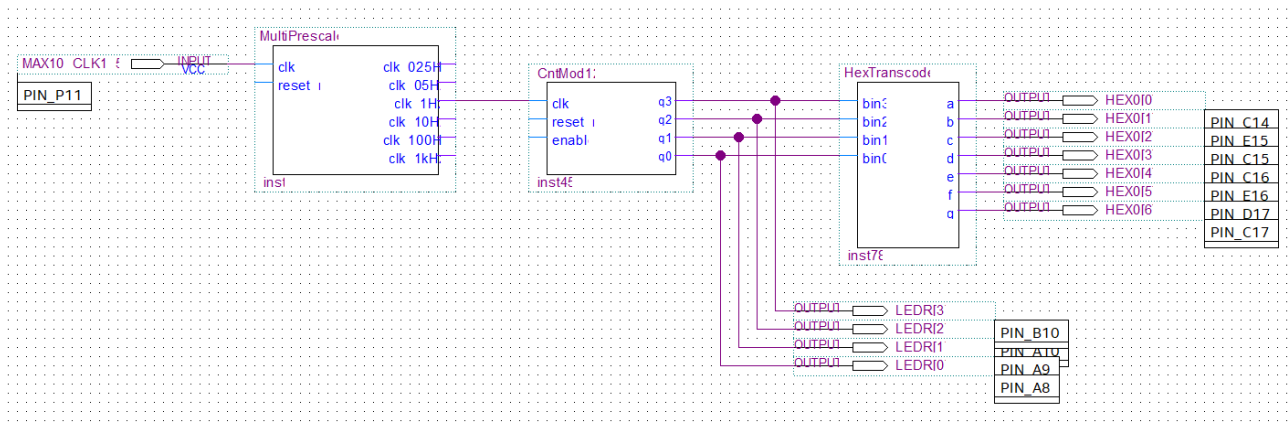
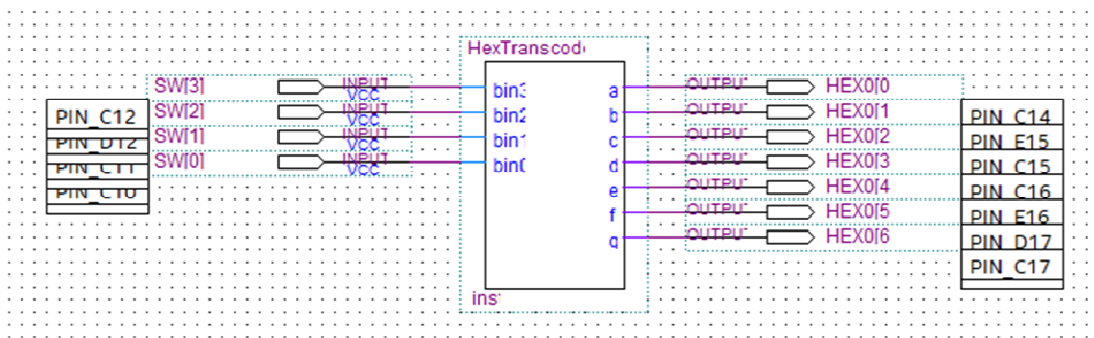

Fig. 3: The electrical connection of the 7-segment display on the DE10-Lite board

In order to test the 7-segment display transcoder use **MultiPrescaler** and **CntMod12** (counter mod 12). Connect modules as in the picture below.



Another possibility to test the implemented module is to connect the switches (SW[3..0]) directly to the inputs, as shown in the picture below.



Transcoder circuit implement as hardware block (create symbol) **(4 pts)**:

- correct project assumption and display connection: **0.5 pts**;
- displayed correctly at least 6 characters on display: **2 pts**;
- displayed correctly all characters: **3.5 pts**;
- created the hardware block (symbol file): **+0.5 pts**.