

Features and limitation of the programmable analogue signal processing for levitated devices

Adam Piłat^{1, a}

¹AGH University of Science and Technology, Department of Automatics,
Mickiewicza 30 Ave, 30-059 Kraków, Poland

^aap@agh.edu.pl

Keywords: Dynamically Programmable Analog Signal Processor, dpASP, Field Programmable Analog Array, FPAA, levitation, control, real-time, active magnetic suspension, active magnetic bearing

Abstract

This paper presents the current state of art in the control systems applied to levitation control and typical structure of digital control system. A new approach based on programmable analogue devices is proposed and an architecture of the levitation controller is presented. Some advantages and disadvantages of the considered technology are given. Finally the possible application of typical control laws and signal processing are discussed. In the experimental example a hard-real time controller implemented in the programmable device is stabilizing a levitated object.

Introduction

Observing the control systems architectures used in the real-time control of levitated devices [2, 6, 15, 16] (suspensions, bearings, etc.) there are three typical groups can be distinguished:

- Digital Signal Processors used as stand alone devices or compact systems developed by dSPACE company,
- Micro-controllers and/or personal computers equipped with a wide range of digital I/O boards,
- Field Programmable Gate Arrays (FPGA) used separately or co-existing with DSPs, micro-controllers, and PCs.

A control algorithm implemented in these devices is usually designed with MATLAB/Simulink software or coded manually in C/C++ or VHDL language. Mathematical formulas are transferred to the digital form with respect to the sampling time and sensor/actuator characteristics.

To achieve the required performance of the control loop, the digital control theory and hardware features ought to be properly used. An increasing sampling frequency and resolution of A/D converters and PWM are observed in order to achieve an improved performance of the levitated devices.

From the control point of view the control signal is produced with a specific and user defined mathematical formula based on one or more measured or observed states.

In the recent research the PC-based control was realized with I/O boards containing both analogue inputs configurations – both with multiplexed [8] and parallel processing [12]. The highest accuracy and bandwidth have been obtained in the case of parallel signal processing. In

the case of control signal applied to the power actuators three technologies have been tested: voltage control, PWM control and current control [8, 9, 12].

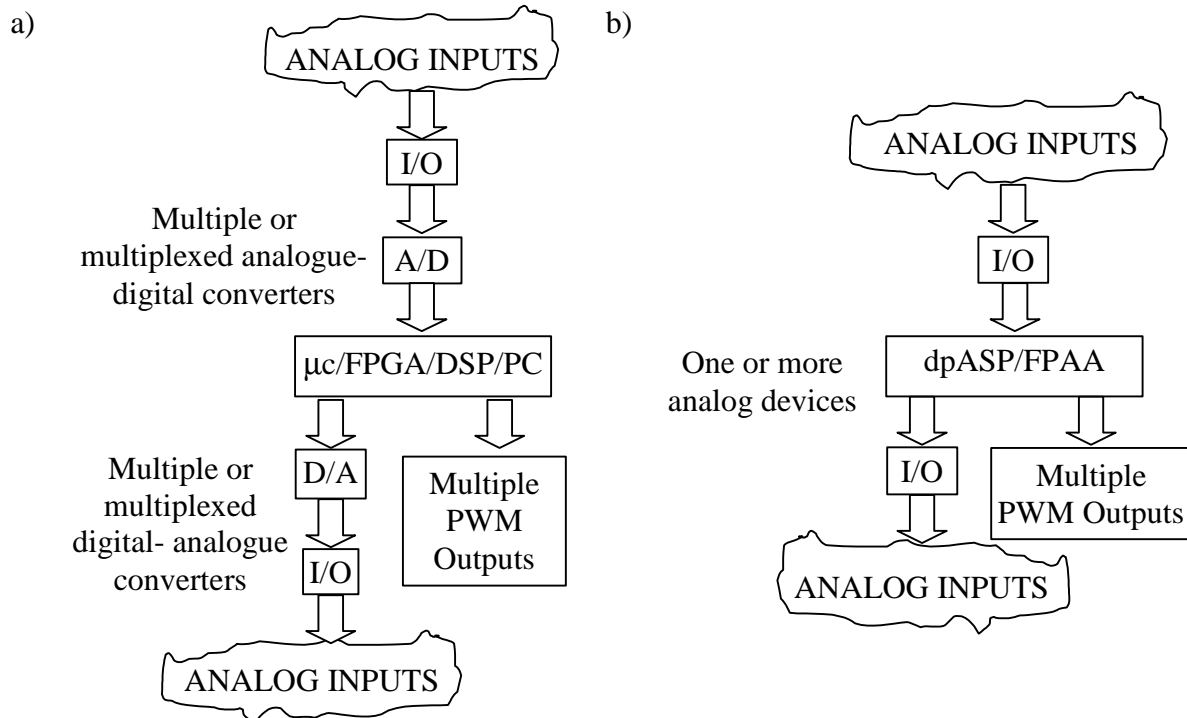

Fig. 1. Configuration of the control system: a) typical digital solution, b) programmable analogue solution

From Figure 1a one can notice that the digital control architecture contains many elements but has a flexible configuration for a wide range of applied control laws. The A/D converters are required to collect data from the real world. The multiplexed or parallel A/D solutions are used. The control signal is applied to actuators in the analogue or digital form using PWM technique. In both cases there are some disadvantages: digital communication (serial/parallel) to/from converter, settling time, PWM resolution and frequency. All these facts make the control hardware very complex.

Case study on Dynamically Reconfigurable Analog Signal Processor

Another technology I am trying to implement in levitated devices is a dynamically programmed Analog Signal Processor (dpASP based on FPAA technology). This technology allows to operate with an analogue signal without digitisation in almost all configurations. It is well known that levitation can be obtained in many ways using discrete analogue elements [6, 9, 17]. However, there are many disadvantages of this method, such as: fixed parameters, drift, non-robust and adaptive feature. Nowadays, the analogue technology can be used in a programmable way with many advantages and features. Levitation has been successfully tested using one chip only [9].

In the case of analogue controller a number of external components necessary in a digital controller construction can be eliminated, thus the control unit simplifies and its costs reduces.

Let us look at the configuration of the analogue controller based on dpASP or FPAA (see Fig. 1b). First of all they are not A/D and D/A converters because the programmable analog unit operates on analogue input/outputs signals, although can generate digital signals too. In

this case the cost is minimized proportionally to the number of input if the parallel A/D processing is realized or minimized by the cost of multiplexer and analogue converter. Moreover, the A/D handling software is not required at all. The same situation occurs in the case of D/A converters. When power actuators require the PWM type signal, it is possible to generate such signal from the FPAA unit [9].

Both analogue and digital controllers are driven by the clock pulses. In the case of programmable analog unit the maximal available clock frequency is 40 MHz, but the sampling frequency depends on used analogue component modules (in some cases it is limited to 2MHz). Another very important feature is that the analogue controller can operate on analogue signals in a parallel way (today only the FPGAs and grid controllers can process digital data in a parallel way). There is no scheduling and multitasking as in microcomputer based applications.

In the analogue controller the most important component are I/O blocks based on op-amps that allows to scale and shift voltage signals to the acceptable range. The precision and low noise op-amps are required for the successful signal processing.

Programmable Analog Controller Architecture

A programmable control hardware is organized in a custom way and contains few dpASPs or FPAAs and the microcontroller. The system can be programmed via serial communication from the host. All analogue devices are connected to the common SPI bus and can be configured from the microcontroller. The system has an availability of initial configuration programming. With this feature all devices are reprogrammed with initial configuration describing their start-up behaviour. This configuration contains predefined configurable analogue modules (CAMs) and their internal connections to obtain appropriate signal flow. The controller starts to operate immediately after initial configuration has been downloaded.

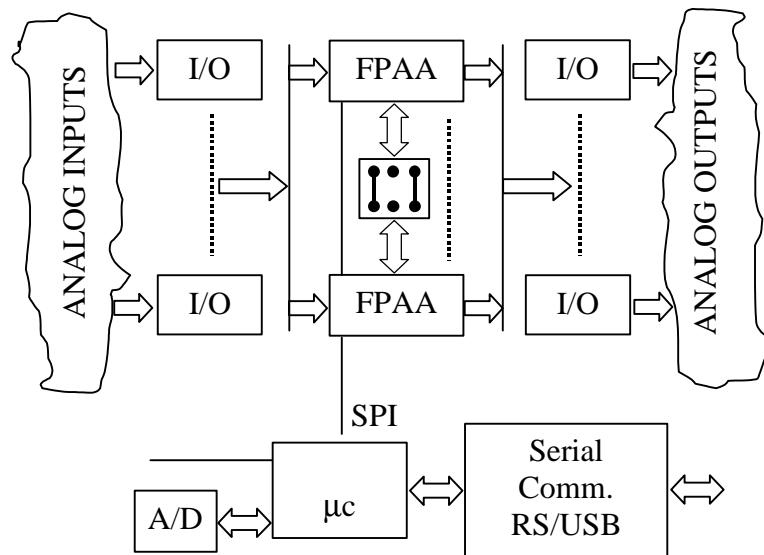

Fig. 2. Mixed structure of the programmable device based on programmable analogue devices

Each of dpASPs (FPAAs) can be reprogrammed remotely by the host microcontroller, where high level functions corresponding to the reconfiguration of appropriate CAMs are

included in the program code. With this feature, for example the controller gain can be modified in a real-time.

The re-configurability feature allows to modify controller parameters on the fly. A control loop based on the presented solution can operate with high frequencies and without the A/D converters it satisfies continuous analogue (although sampled) signal flow. The sampling frequency can be programmed, set in the range of 1kHz to 40MHz, depending on the used analogue modules.

The designed analogue controller architecture is presented in Fig. 2. Note that there are a few dpASPs or FPAA's and their inputs and outputs can be routed together. In this case a single serial controller with a huge capability can be obtained or few parallel signal processing units can operate in a synchronized form.

Till now, four types of the reconfigurable hardware platforms of programmable controllers have been manufactured for the research purposes: multi-board development platform in a stackable form [3], single board controller with dual analogue core [1] and reconfigurable platform with user-defined number of elements for industrial applications [4].

System Capacity and Reconfigurability

The dpAPS or FPAA-based reconfigurable hardware has been developed for a wide range of signal processing prototypes, especially in the field of control applications. Their reconfigurability and simplicity allowed to obtain low cost integrated controller [4]. During the process of prototyping the hardware platforms, we observed a number of advantages and disadvantages related to the applied devices.

Advantages of the realized hardware: direct parallel analogue signal processing via elimination of quantization effects, reconfigurability in the one clock cycle, sampling frequency up to 40MHz, sampling of analog blocks with four different sample rates, library of configurable analog modules (CAMs), chain configuration, reconfiguration for serial and/or parallel signal processing, simple and fast reconfiguration via SPI interface, minimal jitter [14] (in the range of nanoseconds), repeatability of the signal processing, high bandwidth, programmable filtration, integration, safety guaranteed by the hardware,

Disadvantages of the applied technology: small capacity of the FPAA devices, sampling of analogue signals, no EEPROM or FLASH memory - the primary configuration must be loaded from the external device, required external op-amps for the world interface and signal conditioning, sampling of analogue signals, weak multiplication and division calculation, required scaling and signal processing calculations prior to configuration, huge effort in a configuration of complex signal processing. Generally, the programmable analogue devices are a perfect complement for digital reprogrammable devices and simple reconfigurable stand-alone controllers.

Discussion on to-be-implemented controllers

Proportional-Derivative. For SISO configuration, the implementation of a proportional-derivative controller is a necessary minimum required to achieve stable operation of the levitation devices. With a single dpASP 3 PD, controllers can operate in a parallel way with constraints of parameters tuning.

State feedback. In the case of MIMO system the state feedback controller is designed due to its simplicity and energy criterion using LQ approach. In order to apply such controller in the analogue device, it is required to calculate an error of state variables, gain them by a specified value and finally summarize. The capacity of a single FPAA allows to create the 4th order LQ

type controller including two derivative actions for state velocity reconstruction. The gain of particular signal paths can be realized on Sum and Gain CAMs.

Proportional-Integrate-Derivative. The PID consists of two Sum, one Integrator CAMs and one Gain appropriately configured to obtain the signal processing and derivative action. The error can be calculated internally or externally. Placement of two PID controllers is possible, although some constraints appear due to small capacity of the device. It is possible to design a controller operating in a differential mode for a single axis of the AMB (two electromagnets located apart).

High order controllers. In a single FPAA device it is possible to realize up to the 6th (in some cases 8th) order filter in a low pass, high pass, band pass or band stop configuration. Therefore, the transfer function with 6th order nominator and denominator can be configured to adjust zeros and poles.

Other Features. The FPAA devices can be used in the signal processing path to filter the input/output analogue signals. In the case of the digital control, an anti-aliasing filter can be realized. When some parameters of filters (gain, frequency corner, quality) need to be changed during the real-time operation of the controller (analogue or digital) the FPAAs, are a perfect solution. If an extra signal processing is required and some parameters can vary during operation, I recommend using FPAAs. The low cost and simple programmable handling allow to obtain a flexible component in the signal path. The dynamic reconfiguration of the operating circuit is realized by the host micro-controller. This allows to modify signal path parameters in a real-time. The new configuration is downloaded to the chip SRAM and in one clock cycle all necessary components are changed. This feature allows to realize a gain scheduling, variable structure and adaptation controller. The sampling clock can be set in the range of 1Hz – 40MHz using an external oscillator or a micro-controller timer. The full reconfiguration of the FPAA device takes 296 clock cycles. Thus, the control loop performance can be set with respect to the system dynamics.

The programmable controller constitutes an element in an interdisciplinary design of the levitation devices [11]. Its hardware constraints are used at the levitation device designing stage. The analogue controller design method consists of the following steps: modeling and simulation of the closed loop system in SI units, conversion to analogue hardware units, manual or automatic architecture design including constraints, specifics of elements, hardware configuration, experimental verification [13].

In order to apply this technology to the active levitation systems the properties diagram is proposed (Fig. 3). For the description and illustration of the controller properties, the following parameters are proposed: stiffness and damping range, absolute values of current and displacement stiffness, stabilization area - up to 100% of the total levitation gap, frequency of control signal processing [Hz], inverse of controller complexity (number of math operations), parallel measurements and control signal processing, inverse of stabilization accuracy 1/[nm, function of robustness and plug and play, percentage ratio of the stabilization area of the total levitation gap.

The regular polygon shape will reflect the highest performance, quality and advantages of the designed controller.

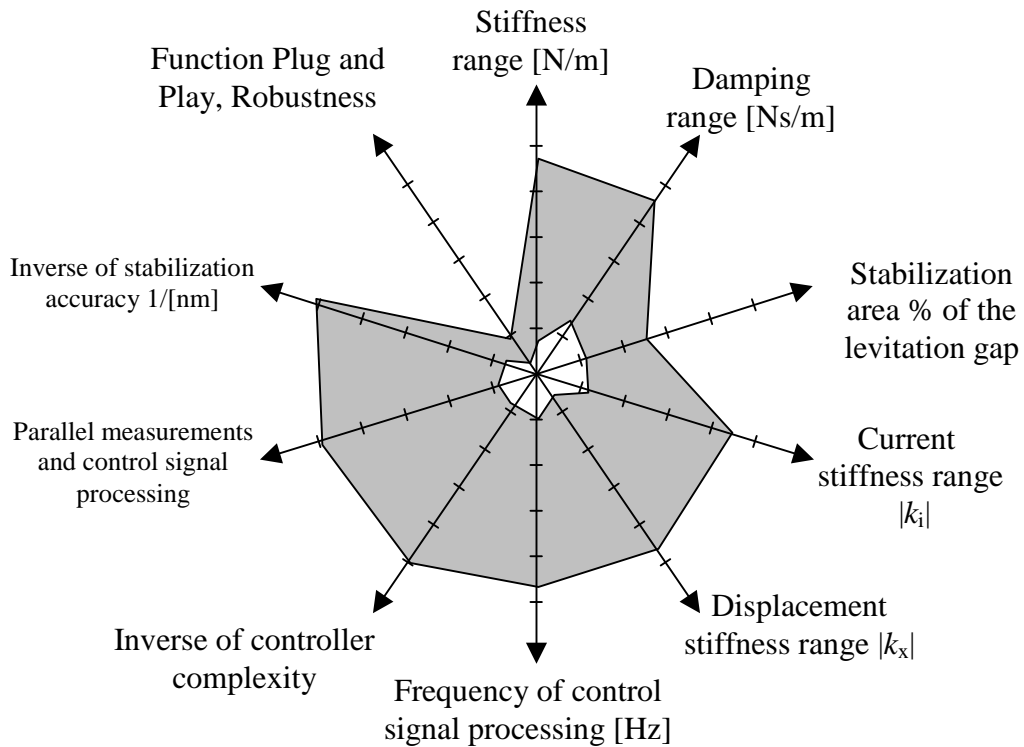

Fig. 3. Proposed diagram for presentation of controller features. Marked area illustrates the performance of the realized controller.

Example - levitated object

To confirm the performance and the proposed methodology, the current driven active magnetic levitation setup MLS2EMi [5] is used. The PD [12] controller implemented (Fig. 4) in a programmable analogue device is steering the electromagnet keeping the object levitated. The controller is based on configurable analogue modules with adjustable gains.

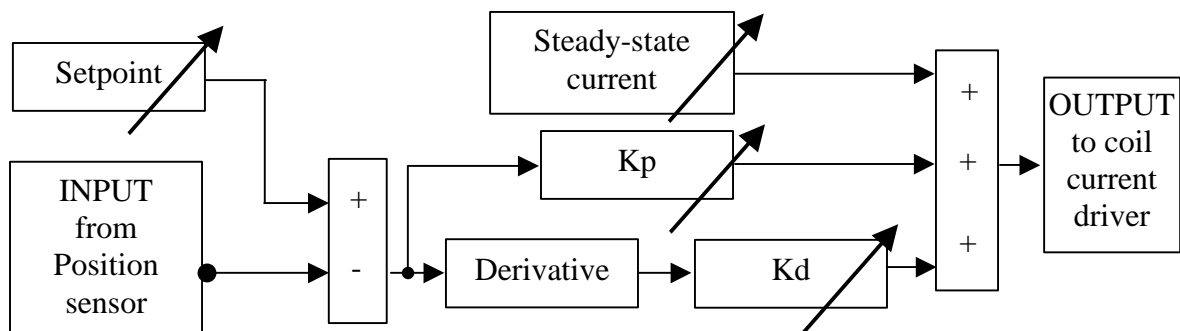

Fig. 4. Architecture of the programmable PD analogue controller.

The closed loop sampling rate was set to 100kHz. Figure 4 presents the levitated sphere and position and control signals stored on the oscilloscope with 20mV and 20ns graduation (Fig. 5).

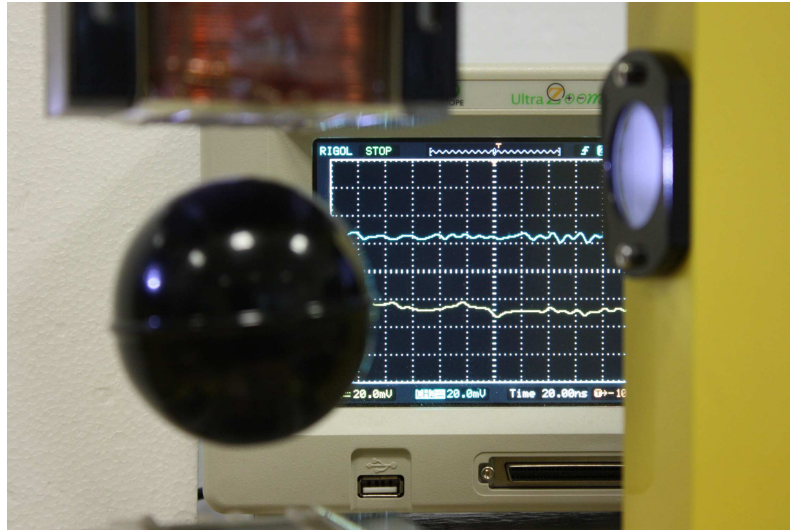

Fig. 5. MLS2EMi controlled by the programmable analogue device

Compared to digital control, the applied analogue control is realized by the programmable hardware. It is fast and flexible and thus the control parameters can be adjusted and adapted in a real-time.

Current research

Having the theoretical aspects and real time experiments already performed using PC based architecture, I'm testing an implementation of SISO, MISO, MIMO linear controllers for the magnetic levitation systems [8, 14] and AMB. The next stage will be focused on the controller adaptation and nonlinear control law implementation in the programmable analogue form. The realized and experimentally verified control strategies will be compared.

Conclusions

A. Einstein said: *Make everything as simple as possible, but not simpler.* In my opinion this sentence reflects the application of an programmable analogue devices for control purposes a specially in the field of active levitation.

With the presented hardware the number of signal processing methods can be applied in the analogue form. The overall capacity of three FPAA devices connected in a serial way allows to realize e.g. a high order filters, nonlinear controllers, observers, neural networks and solve differential equations. Working with parallel signal flow, a number of PD, PID, LQ controllers, simple filters can operate independently but synchronously. Moreover the signal flow is done in a parallel way and thus time delays do not occur and the controller law could be simplified and its performance increases.

Anyone interested in this technology is welcome to visit the web page related to the programmable analogue controller project for active magnetic bearing control [4].

Acknowledgement

This research was supported by the Polish Scientific Research Grant No 3585/B/T02/2009/37

References

- [1] Baliński P., Programmable analog-digital architecture for control purposes (in Polish), Master Thesis, Supervisor: Adam Piłat, AGH 2009
- [2] Chiba A. et al., Magnetic Bearings and Bearingless Drives, Newnes, 2005.
- [3] Klocek J., Hajduk M. Implementation of control laws in a programmable analogue devices (in Polish), Master Thesis, Supervisor: Adam Piłat, AGH 2008
- [4] Information on <http://home.agh.edu.pl/~ap/PAC>
- [5] Magnetic Levitation System MLS2EMi, Users Guide, 2008, INTECO, Kraków, Poland
- [6] Maslen, E. (1995). Magnetic Bearings. University of Virginia, Department of Mechanical, Aerospace and Nuclear Engineering, Charlottesville, Virginia, 1995.
- [7] Okhrimenko V. L., Shurubkin V. D., Magnetic suspension with a tuned circuit, Izmeritelnaya Tekhnika, No. 10, p. 89, October, 1976.
- [8] Piłat A, Control of Magnetic Levitation Systems, Ph.D. Thesis (in Polish), AGH University of Science and Technology, Department of Automatics, Poland, Krakow 2002
- [9] Piłat A., Programmable analog hardware for control systems exemplified by magnetic suspension, Computer Methods and Systems, Cracow, Poland 14-16 November 2005,
- [11] Piłat A. Active magnetic suspension and bearing. Modeling and simulation. eds. Giuseppe Petrone, Giuliano Cammarata. Vienna: InTech Education and Publishing, 2008, ISBN 978-3-902613-25-7, pp. 453–470
- [12] Piłat A., Stiffness and damping analysis for pole placement method applied to active magnetic suspension (in Polish), Automatyka, ISSN 1429-3447. 2009 vol. 13 no. 1 pp. 43-54
- [13] Piłat A. Semi-automatic design and code generation for FPAA devices. Computer Methods and Systems, 26–27 November 2009, Kraków, Poland — ISBN 83-916420-5-4. pp. 375–378
- [14] Piłat A.: Hard and soft real-time in application of programmable analog device (in Polish). Trybus L., Samolej S. (ed.) Methods of manufacture and application of real-time systems, WKŁ, 2010, pp. 343-352.
- [15] Proceedings of the International Symposium on Active Magnetic Bearings (1988-2006)
- [16] Schweitzer G., Maslen E.H. (Eds.), Magnetic Bearings, Theory, Design, and Application to Rotating Machinery, Springer, 2009.
- [17] Sinha, P. K., Electromagnetic Suspension. Dynamics & Control. Peter Perginus Ltd., London. 1987